

Central-Loc - Technical Sheet

24" Standard Profile (18" Optional)



24" MS3 Profile (Verify Price, Color, Availability)



COMMERCIAL
INDUSTRIAL
PANEL

CONCEALED
FASTENED

24"
COVERAGE

MINIMUM
SLOPE
1/4:12

OPEN FRAMING OR
SOLID SUBSTRATE

PANEL OVERVIEW

- ▶ Finishes: PVDF and Acrylic-Coated Galvalume®
- ▶ Corrosion Protection: AZ55 per ASTM A 792 for unpainted Galvalume®
AZ50 per ASTM A 792 for painted Galvalume®
G90 per ASTM A 653 for Galvanized
- ▶ Gauges: 24 ga standard; 22 ga optional
- ▶ 24" panel coverage, 3" rib height
- ▶ Panel Length: Minimum: 5'; Maximum: 45' recommended
- ▶ Structural, trapezoidal standing seam roof system
- ▶ Snap-together side lap with factory-applied sealant in panel and clip
- ▶ Minimum roof slope: 1/4:12
- ▶ Panels can be factory-notched and punched
- ▶ Accommodates 1/2" to 6" blanket insulation

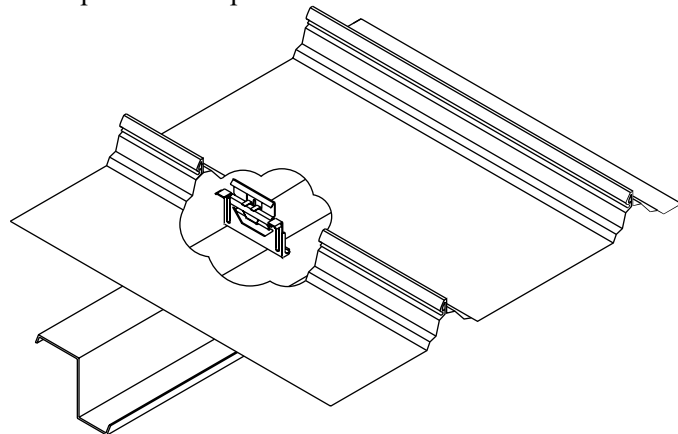

TESTING AND APPROVALS

- ▶ UL 2218 Impact Resistance - Class 4
- ▶ UL 790 Fire Resistance Rating - Class A, per building code
- ▶ UL 263 Fire Resistance Rating - per assembly
- ▶ ASTM E 1680 Air Leakage - 0.005 cfm/ft² at 6.24 psf
- ▶ ASTM E 1646 Water Penetration - none at 20 psf
- ▶ ASTM E 1592 Structural Performance
- ▶ UL 580 Uplift Resistance - Class 90 - See Report for Requirements



BEST BUY METALS
Roofing That Lasts

Central-Loc - Technical Sheet

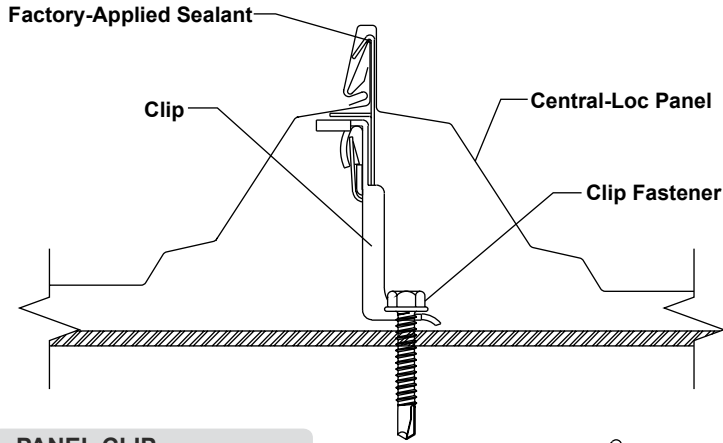
ATTACHMENT DETAIL

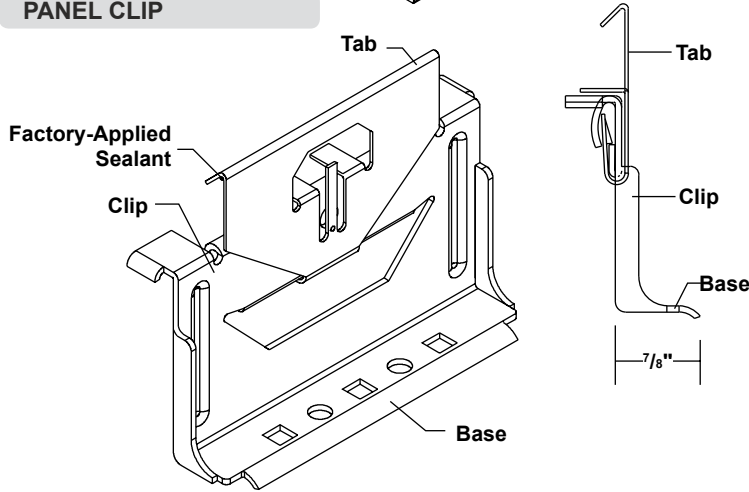

PANEL CLIP



FASTENING INFORMATION

► Clips

Clip spacing is based upon the design loads, the spanning capacity of the panels, the fasteners and the support members.

Clip Tabs are 0.037" thick, G90. Clip base is 0.064" thick, G90.

Floating Clips can accommodate 1-1/8" of thermal movement each way.

► Fasteners

Overdriven fasteners will cause panel distortions.

Fasteners should extend 1/2" or more past the inside face of the support material.

Clip Fasteners:

Attaching to Wood:

#10-12 Pancake Head Wood Screw

Attaching to Steel:

<18 ga: 1/4"-14 Deck Screw

>=18 ga, <=12 ga: 1/4"-14 Driller, No Washer

>12 ga: 1/4"-24 Driller, No Washer

Exposed End Fasteners:

Attaching to Eave Plate or Compression Plate:

#12-14 XL Driller

Concealed End Fasteners:

Attaching to Compression Plate:

1/4"-14 Driller, No Washer

Trim Fasteners:

1/4"-14 x 7/8" XL Stitch Screw

SECTION PROPERTIES

Ga	Width in	Yield ksi	Weight psf	Top In Compression		Bottom In Compression	
				Ixx in ⁴ /ft	Sxx in ³ /ft	Ixx in ⁴ /ft	Sxx in ³ /ft
24	24	50	1.14	0.3070	0.1271	0.1250	0.0819
22	24	50	1.49	0.4060	0.1679	0.1750	0.1117

ALLOWABLE UNIFORM LOADS, psf For various clip spacings

								Inward Load					Outward Load						
								2'	2.5'	3'	3.5'	4'	5'	2'	2.5'	3'	3.5'	4'	5'
24	24	50	1.14	0.3070	0.1271	0.1250	0.0819	418	280	199	149	115	75	28	26	25	23	21	18
22	24	50	1.49	0.4060	0.1679	0.1750	0.1117	578	385	274	204	158	102	35	33	31	28	26	22

- Theoretical section properties have been calculated per AISI 2012 'North American Specification for the Design of Cold-Formed Steel Structural Members'. Ixx and Sxx are effective section properties for deflection and bending.
- Allowable loads are calculated in accordance with AISI 2012 specifications considering bending, shear, combined bending and shear, deflection and ASTM E 1592 uplift testing. Allowable loads consider the 3 or more equal spans condition. Allowable loads do not address web crippling, fasteners or support material. Panel weight is not considered.
- Deflection consideration is limited by a maximum deflection ratio of L/180 of span.
- Allowable loads do not include a 1/3 stress increase for wind.